

Needles: 4, 6.5

Size: 50

Gauge: 28 sts 40 rws per 10cm

Estimated Ydg: 470

Back

With rib needle, cast on 82 sts.
 Estab rib pat on Row 1: *K2 ,
 P2. Repeat from *. End K2.
 Work 13 rws. On row 14,
 increase as below. [3 cm].

Rib-to-Body Inc Row

2 incs. [Work 27, inc 1 in next
 st, work 26, inc 1 in next st] 1x,
 work 27. (84 sts)

With body needle, work in pat st
 until piece meas 17"[row 56].

Armhole Shaping

Bind off 6 sts at beg of next 2
 rws. Dec 1 st each side, every
 other row 6x.

Cont in pat st until piece meas
 29 cm from start [row 104].

Shape Shoulders

Bind off 5 sts beg of next 2 rws.
 Bind off 5 sts beg of next 2 rws.
 Bind off 6 sts beg of next 2 rws.
 Bind off 28 back neck sts.

Front

make two, [reversing shaping]
 With smaller needles, cast on
 42 sts.

Estab rib pat on Row 1: *K2 ,
 P2. Repeat from *. End K2.
 Work 14 rws total in rib pattern.
 [3 cm]
 Work as for back, including
 all shaping,

and, at the same time
 when piece meas 24.5 cm [row
 86]

Begin Neck Shaping

At neck edge, bind off 7 sts
 Bind off 2 sts at each neck edge
 1x

Dec 1 st at neck edge,
 every other row 5x.

Cont in pat st until piece meas
 29 cm from start [row 104].

Shape Shoulders

Work shoulder shaping (at
 shoulder edge) to correspond
 with back.

Work sleeves. (pg 2)

Continued on page 2.

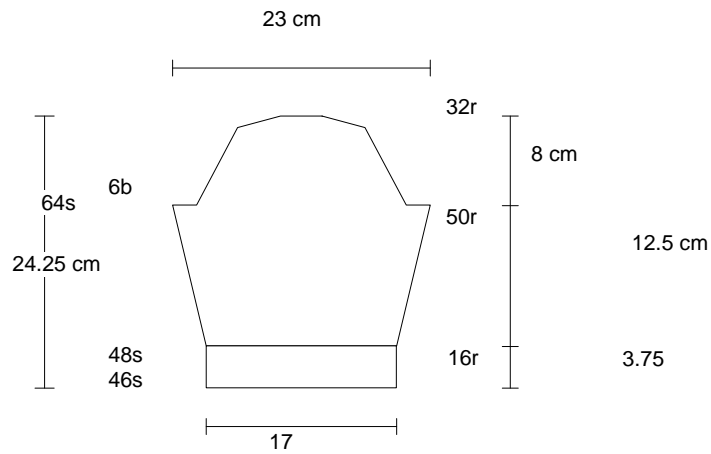

Sleeves

With smaller needles, cast on 46 sts.

Work same as body rib for 15 rws [3.75 cm]. On the next rib rw:

Cuff-to-Sleeve-Inc Row

[Work 15, inc 1 in next st, work 14 inc 1 in next st] 1x, work 15.

Sleeve Shaping

Using larger needle, work one RS row. Begin sleeve shaping: Inc 1 st on each side every 4th rw 1x, then every 6th rw 7x.

Cont in pat st until piece meas 16.25 cm [row 50].

Cap Shaping

Bind off 6 sts each side.

Dec 1 st each side, every other row, 6x

Dec 1 st each side every 2nd rw 10x.

Bind off 2 sts at the beg of next 4 rws.

Bind off rem 12 sts.

Join seams.

Weave in all ends.

Seam each shoulder. (16 sts)

Neck Finishing

Using smaller needle and RS facing, pick up 7 bound off sts from right front, pick up 2 sts from side bind off, pick up 18 side neck sts, pick up 28 back neck sts, pick up 18 left side neck sts, pick up 2 sts from side bind off, pick up 7 bound off sts. Working back and forth, estab pat. Inc or dec as necessary on the first row to balance pattern. Work for 2.5 cm. Bind off loosely in pat.

Bands

Finishing Bands: Right Front
With smaller needles and RS facing, pick up 84 sts. Work 2.5cm in rib, end WS.

Bind off neatly.

Left Front

Repeat instructions for right front.